



October 7, 2019

TSSA
345 Carlingview Drive
Toronto, ON M9W 6N9

Dear Tanya Francis
Re: Reciprocal CRN Registration in Manitoba

Your application indicates that a CRN has been received in another Canadian Jurisdiction, and therefore your CRN has been registered in Manitoba as follows:

File Number: 74-R215
CRN: 0D21781.54
Scope: Attachment A and B for Scope of Registration
Manufacturer: SWAGELOK COMPANY

Please find attached invoice for registration.

As indicated by the Regulatory Reconciliation and Cooperation Table and the Reconciliation Agreement for the Canadian Registration Number (CRN) for Pressure Equipment, a CRN issued in any Canadian Jurisdiction will be accepted for use in Manitoba.

In accordance with Steam and Pressure Plants Regulation and CSA B51, it is the manufacturer's responsibility to file a Manufacturers Data Report, including partial data reports, with our office, prior to shipping pressure equipment to Manitoba.

Please contact me directly via email at Cheryl.Lashek@gov.mb.ca for any questions or concerns.

Cheryl Lashek, P.Eng
Director, ITSM
Inspection and Technical Services
Office of the Fire Commissioner
508 - 401 York Avenue, Winnipeg Manitoba R3C 0P8
T (204) 945-3507 | F (204) 948-2309



Technical Standards and Safety Authority
 345 Carlingview Drive
 Toronto, Ontario M9W 6N9
 www.tssa.org

Show facsimile of manufacturer's logo or trademark, as it will appear on the fitting, in the space below

Swagelok

STATUTORY DECLARATION Registration of Fittings

I, Joel Feldman, Vice President of Engineering
(Name and Position, e.g. President, Plant Manager, Chief Engineer)

of Swagelok Company
(Name of Manufacturer)

Located at 29500 Solon Road, Solon, Ohio 44139 USA (Plant Address) (440) 248-4600 (Telephone No.) (440) 349-5970 (Fax No.)

do solemnly declare that the fittings listed hereunder, which are subject to the **Technical Standards and Safety Act**, Boilers and Pressure Vessels Regulation, comply with all of the requirements of ASME B31.3 for unlisted components

(Title of recognized North American Standard)

which specifies the dimensions, materials of construction, pressure/temperature ratings, identification marking the fittings and service;

or are not covered by the provisions of a recognized North American standard and are therefore manufactured to comply with _____ as supported by the attached data which identifies the dimensions, material of construction, pressure/temperature ratings and the basis for such ratings, the marking of the fitting for identification and service.

I further declare that the manufacture of these fittings is controlled by a quality system meeting the requirements of ISO 9001:2015 which has been verified by the following authority, BSI

The items covered by this declaration, for which I seek registration, are category D. Hose type fittings. In support of this application, the following information and/or test data are attached as follows:

ISO 9001:2015 Certificate, Attachment A, Attachment B, Catalog Information and other Support Documents

(drawings, calculations, test reports, etc.)

Declared before me at Solon in the state of Ohio

the 18th day of July AD 20 19.

Commissioner for Oaths:

Brenda Hammel
(Printed name)

Brenda Hammel
(Signature)

[Signature]
(Signature of Declarer)

FOR OFFICE USE ONLY

To the best of my knowledge and belief, the application meets the requirements of the **Technical Standards and Safety Act**, Boilers and Pressure Vessels Regulation, and CSA Standard B51 and is accepted for registration in Category D

CRN: 0021780.5

Registered by: [Signature]

Dated: Sept. 15, 2019

NOTE: This registration expires on: Sept. 15, 2029

Technical Standards and Safety Authority **Boilers and Pressure Vessels Safety Program**

REGISTERED

C.R.N.: 0021780.5

Signed: [Signature]

Date: Sept. 15, 2019

*Information provided in this application is releasable under the Freedom of Information and Privacy Protection Act and may be disclosed upon request.

PV 09553 (04/17)

For scope of registration see stamped attachment A and attachment B.

Attachment B: Scope of Registration for Swagelok FL Series Hose Assemblies (Category D)

The table below represents the scope of Swagelok FL series hose assemblies covered by this submission for CRN approval. These hose assemblies have been evaluated in accordance with ASME B31.3:2016 Process Piping as unlisted components. The referenced port connections and product catalog(s) do not represent the full scope of the submission but rather detail some of the most common options.

Summary Table

Product Series	Pressure Retaining Material	Nom. Hose Size (in)	End Connections & Sizes	Maximum Working Pressure (psig)		Design Code of Construction		
				Up to 100°F	@ Max. Temp.			
FL Series Metal Hose	<div style="border: 2px solid red; padding: 5px; margin-bottom: 10px; color: red; font-weight: bold;"> THIS IS PART OF CRN 0021780.5 Technical Standards & Safety Authority Boilers & Pressure Vessels Safety Program </div> <p>Core 316L SS (EN 10088-2)</p> <p>Braid 321 SS (EN 10088-3)</p> <p>End Connections Strain-Hardened 316 SS, 316L SS, or 316LV SS (ASTM A479)</p>	1/4	Tube Fitting [TA, TM, SL, SM] 1/4" – 1/2" (6mm – 10mm) Male & Female VCR Metal Gasket Face Seal Fittings [RM, RF] 1/4" – 1/2" SAE 37° (JIC) Female Swivel [AS] 1/4" – 3/8" Tube Butt Welds [TB] 1/4"	1500	840 @850°F	ASME B31.3 (Unlisted Components)		
			Female VCO O-Ring Face Seal Fittings [VF] 1/4"				1500	975 @500°F
			Male & Female Pipe Threads, NPT [PM, PF] 1/4" – 1/2" ISO/BSP Tapered (ISO 7) [MT][FT] 1/4" – 1/2"				1500	1050 @400°F
		1/2	Tube Fitting [TA, TM, SL, SM] 1/4" – 3/4" (6mm – 18mm) Male & Female VCR Metal Gasket Face Seal Fittings [RM, RF] 1/4" – 3/4" SAE 37° (JIC) Female Swivel [AS] 1/2" – 5/8" Tube Butt Welds [TB] 1/2"	1200	672 @850°F			
			Female VCO O-Ring Face Seal Fittings [VF] 1/2"				1200	780 @500°F
			Male Pipe Threads, NPT [PM] 1/4" – 3/4" Female Pipe Threads, NPT [PF] 3/8" – 1/2" ISO/BSP Tapered (ISO 7) [MT][FT] 3/8" – 1/2"				1200	840 @400°F

Product Illustration

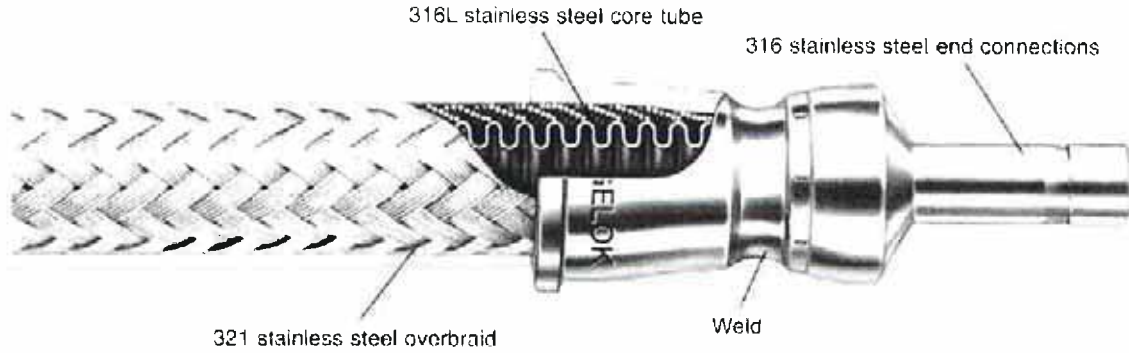

Configuration Example:

FL hoses are available in two sizes with many end types, end sizes, and possible overall lengths.

The corrugated tubing and braid are attached to the end connection with a Gas Tungsten Arc Weld (GTAW) cap weld process.

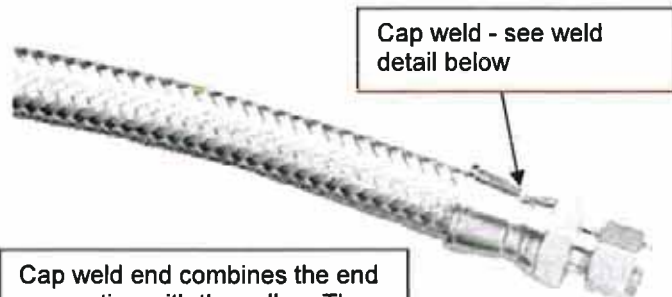

Cap weld end combines the end connection with the collar. The part is welded within the groove after crimping.

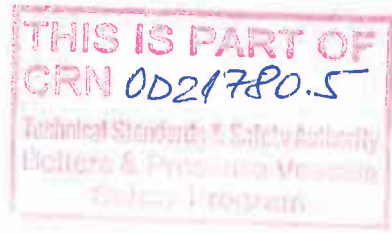

Weld Detail:

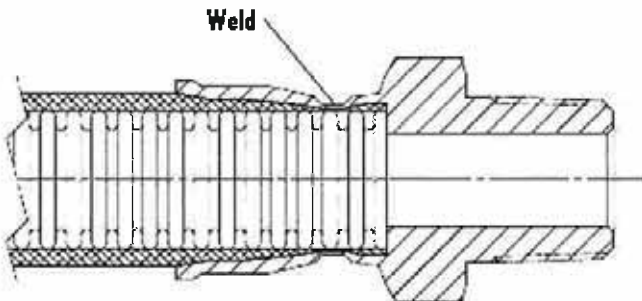

Product Options:

Additional options and non-pressure boundary alterations that do not affect pressure ratings may be made available within the scope of this approval. Examples of these would include the following:

- Cover Options (ex. fire jacket, thermosleeve, etc.)
- Tag and Marking Options (ex. tags, lanyards, retaining clamps, etc.)
- Special Testing Options (ex. hydrostatic pressure test, inboard helium leak test, nitrogen leak test, etc.)
- Other Options (ex. traceable certificates for product).

Additional options that may affect pressure and/or temperature ratings may be made available within the scope of this approval. Examples of these would include the following:

- End Connection Seals or Sealant Options (ex. VCO O-rings, VCR gaskets, pipe thread sealant, etc.)

Quality System

The Swagelok Company quality system complies with the requirements of ISO 9001:2015. The Swagelok Company maintains BSI Certificate of Registration Number FM 01729, which applies to all locations listed on the Certificate.

References

The below product catalog does not represent the full scope of the registration but rather details some of the most common options.

- Hose Assemblies, Bulk Hose, and End Connections Product Catalog MS-01-180, Rev. S



Attachment A. Swagelok Manufacturing Locations

This document lists the Swagelok locations where end item or component level manufacturing activities take place.

Swagelok Company 29500 Solon Road Solon, Ohio 44139 USA	Swagelok Company (Falon 1) 348 Bishop Road Highland Heights, Ohio 44143 USA
Swagelok Company (Highland) 318 Bishop Road Highland Heights, Ohio 44143 USA	Swagelok Company (Falon 2) 358 Bishop Road Highland Heights, Ohio 44143 USA
Swagelok Company (OFC) 29495 F.A. Lennon Drive Solon, Ohio 44139 USA	Swagelok Company (HPF) 6050 Cochran Road Solon, Ohio 44139 USA
Swagelok Company (Atlantic) 26651 Curtiss Wright Parkway Willoughby Hills, Ohio 44092 USA	Swagelok Company (Snow Metal) 6060 Cochran Road Solon, Ohio 44139 USA
Swagelok Company (Micro) 26653 Curtiss Wright Parkway Willoughby Hills, Ohio 44092 USA	Swagelok Company (Alfred) 29500 Ambina Drive Solon, Ohio 44139
Swagelok Hose Services Company (SHSC) 29900 Solon Industrial Parkway Solon, Ohio 44139	Swagelok Company (Strongsville) 15400 Foltz Road Strongsville, Ohio 44119
Swagelok (China) Fluid System Technologies Ltd. Changshu Export Process Zone Changshu Economic Development Zone Changshu, Jiangshu 215513 China	Swagelok Limited Ballafletcher Road Tromode IM4 4RA Isle of Man

